

## Tensile Test Facility for Temperatures up to 1900 °C

### Key words

Tensile test, high temperature test, composite materials, LCF

### Fields of application

Tensile tests for the determination of mechanical properties up to 1900 °C in inert gas and under vacuum and up to 1600 °C in air

### Methodology and instrumentation

A 100 kN servo-mechanical testing machine is used with an integrated small chamber containing either an inert gas or vacuum. The specimen is induction heated either by insulating materials with susceptors and heat radiation. For tests in air up to 1600 °C special susceptor materials are provided. For the strain measurement an integrated high temperature extensometer is used.

### Items tested

Flat tensile specimens, thickness up to 12 mm and length greater than 200 mm

### Quantities / characteristics tested

Tensile strength, yield strength, strain at failure, Young's Modulus, low cycle fatigue

### Uncertainty / reliability of results

Relative uncertainty for a 95 % confidence level: 5 % (depending on the number of tests)

### Qualification and quality assurance

Only test facility of this kind in Germany which can carry out tests in air up to 1600 °C.  
Other test facilities operate under vacuum or inert gas exclusively.  
Extensive experience; numerous publications; participation in standardisation of test methods.

<b>Contact:</b>	Dr.-Ing. Birgit Rehmer	<b>Phone:</b>	+49 30 8104 1522
<b>E-mail:</b>	<a href="mailto:birgit.rehmer@bam.de">birgit.rehmer@bam.de</a>	<b>Fax:</b>	+49 30 8104 1527
<a href="#">Division 5.2 - Mechanical Behaviour of Materials</a>			<a href="#">back to Catalogue of Unique Test Facilities</a>

Further information

High-temperature tensile testing

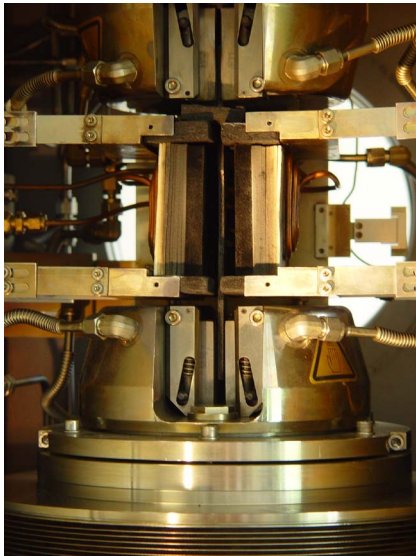

The testing device was conceived for the determination of mechanical properties of ceramic composites, for tests in vacuum and inert gas up to 1900 °C and in air up to 1600 °C. The sample is heated by using induction heating combined with susceptor plates for insulating materials.

Load cell: 100 kN

Literature

- DIN EN 1893**  
Advanced technical ceramics – mechanical properties of ceramic composites at high temperature in air at atmospheric pressure – determination of tensile properties
- DIN V ENV 1892**  
Advanced technical ceramics – mechanical properties of ceramic composites at high temperature under inert atmosphere – determination of tensile properties
- ASTM C 1359**  
Standard Test Method for Monotonic Tensile Strength Testing of Continuous Fiber-Reinforced Advanced Ceramics with Solid Rectangular Cross-Section Specimen at Elevated Temperatures

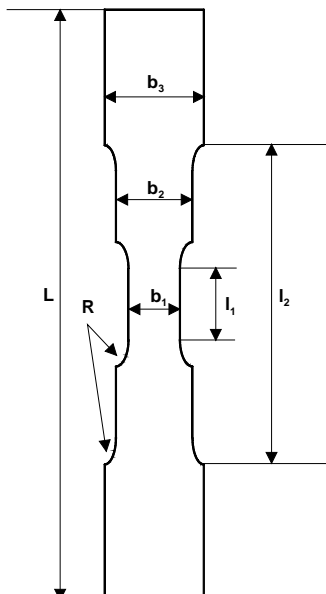
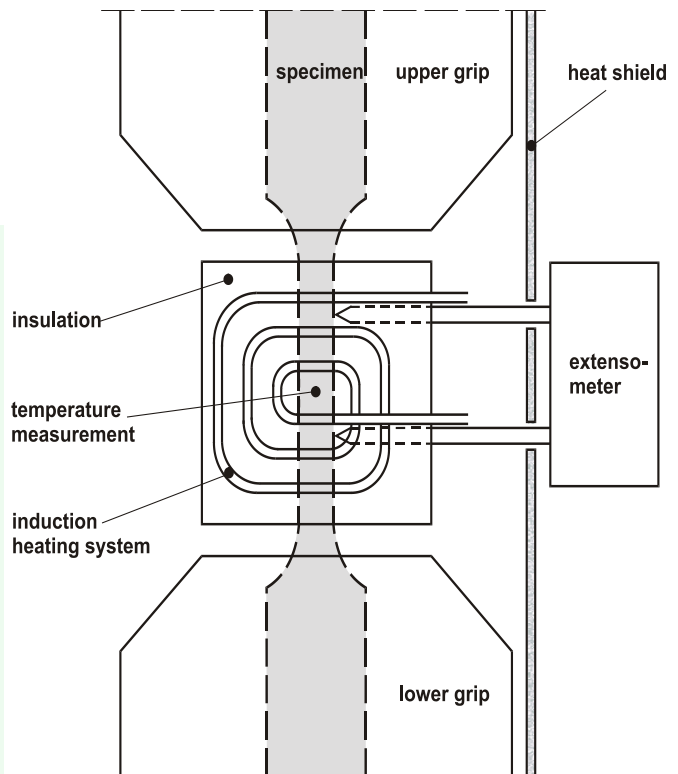

Example for dimension (ceramic composite)

Flat specimen with rectangular cross section

- L = 210 ± 0.5 mm
- l<sub>1</sub> = 30 ± 0.2 mm
- l<sub>2</sub> = 110 ± 0.2 mm
- b<sub>1</sub> = 15 ± 0.1 mm
- b<sub>2</sub> = 20 ± 0.2 mm
- b<sub>3</sub> = 25 ± 0.2 mm
- R = 30 ± 2 mm